

WATERKOTTE heat pump innovation

DS 5050 T

- series provided with tandem compressors

DS 5050 T (Compact)

Performance range 23 to 50 kW, 4 power levels

The Innovation

- + More security by using two compressors with automatic basic load change
- + Less energy consumption by automatic optimization 50 % / 100%
- + Reduction of starting current by 50%
- + More efficient
- + Less noise
- + COP counter, integrated energy saving control, now part of standard equipment. Thus, watch your heat pump save you money.
- + Telemonitoring and remote visualisation is possible.



The geothermal heat pump system was developed in 1969 by WATERKOTTE and represents a revolution in heating technology, since mankind has been using fire as fuel for 1.5 million years. Take advantage of our experience, assisted by one of our long-time installation partners near you.

Geothermal heating is the only sustainable solution, now and in the future

More economical than ever

... this idea was realized by Clemens Oskar Waterkotte in 1969 in his own new house. Here, at the beginning of 1970 the first WATERKOTTE geothermal heating went into operation.

It was a success from the beginning

... more economical than the most economical heating – that was at a time when oil heating was run at under 9 cents per litre.

The secret of success

... was and is to be found in the heat source and properly used, optimized complete system technology from the beginning.

The optimal heat source

... is the soil, because soil temperature is closest to ambient room temperature:

- + heat source, geothermal temperature + 12 degrees C
- + heat use, room temperature + 22 degrees C

The minimal temperature difference of only ten degrees C is the optimal prerequisite for geothermal pump heating. The smaller this difference, the higher the efficiency of the heat pump.

This is the only way it is possible to cover the heat requirements of the building as efficiently with energy from the sun.

Heat pump – what is that?

In the Stone Age, humans learnt how to deal with fire, and were able to use this to heat themselves. The fireplaces have changed since then, but apart from that, nothing else has. Fire has remained, 1.5 million years without a noticeable change, until 1970, Klemens Oskar WATERKOTTE revolutionised the world of heating technology. Since then, his technical development has made it possible to heat without fire, just by using renewable geothermal energy.

To do this, he was able to refer to Carl von Linde's "cold machine", which he patented in 1876. The "heat pump" differs only in name and use.

- + cold machine – use of the cold side
- + heat pump – use of the warm side

Geothermal pump heating is the solution

The heat pump alone cannot heat. To supply heat, it requires heat pump heating systems.

What does a heat pump heating system consist of?

In general, it consists of

- + the heat source
- + the heat pump
- + the heat distribution system.

What did WATERKOTTE achieve by doing this?

- + He developed the heat source technology and the proper sizing of the processes
- + He developed and calculated the highly efficient underfloor heating system
- + He developed the first effective heat pump central heating

What determines the quality of the heat pump heating system?

The degree of efficiency and consumption can only be calculated from the quality of the complete system together with the temperature behaviour of the heat source and the heat sink during use over a whole heating season. Accordingly, it makes little sense to measure and compare the efficiency of the heat pump alone.

Is there a possibility to measure or compare the quality of a system?

Yes, through measuring and comparison of the annual energy rate in neutral field tests over a complete heating period. That is the only possibility for objective comparison.

In these tests, WATERKOTTE was always in a class of its own at the top, with annual energy rate of 4.5+.

How can one compare the performance of the heat pump heating unit?

Test results displayed in sales literature are only valid for the heat pump; this is as if one would judge a car by its engine alone.

The comparison with the car

- + The heat pump is equivalent to the engine,
- + The complete heat pump heating unit is equivalent to the car,
- + The energy rating results from field tests throughout a heating period are equivalent to statements made about values for the real functioning of a car in real conditions.

Is there a guarantee for the annual energy rate?

Yes, at WATERKOTTE in connection with TERAMEX geothermal probes and the delivery and assembly by certified WATERKOTTE partner installers, a geothermal share of over 75 %. This is guaranteed for 10 years and will be achieved for 10 years.

How does one obtain geothermal energy?

Basically there are three methods:

- + Groundwater extraction, cooling and reintroduction (intermediate heat exchanger required)
- + soil surface collectors at the relevant depths (not particularly suitable for natural cooling)
- + TERAMEX geo-energy probes (the optimal solution, guarantee of annual energy rate, natural cooling possible)

How does one measure heat pump heating systems?

Only neutrally obtained energy ratings are useful. Measuring data from tests are worthless. WATERKOTTE heat pumps with TERAMEX geothermal energy are the only leader with guaranteed results for 10 years.

The new solution for large buildings DS 5050T

The series was especially developed for use in large residential buildings, where minimal space requirement, minimal noise and high efficiency is required. The standard model with two equally sized compressors automatically adapts to load.

This design has even more advantages:

- + Together with the electronic Motor Power Management Module (EMPM Module), the start-up current can be limited to 30 A.
- + The possibility of cascading up to 4 units is a special solution.
- + As normally only one compressor is in use, the energy rate is greatly improved.
- + The alternate switching at every start ensures a higher life expectancy.

Technical description

- + The electric Motor Power Management, EMPM, prevents the restarting process in the case of phase failure and ensures a soft start at maximum 30 A and a soft shut-off (compressor stops without a thud).
- + The built-in electronic expansion valve ensures optimal operating conditions in all load conditions.

Automation

The device is fitted with the improved control unit WPCU, which makes network connection via plug-in modules possible (connection to central building control systems).

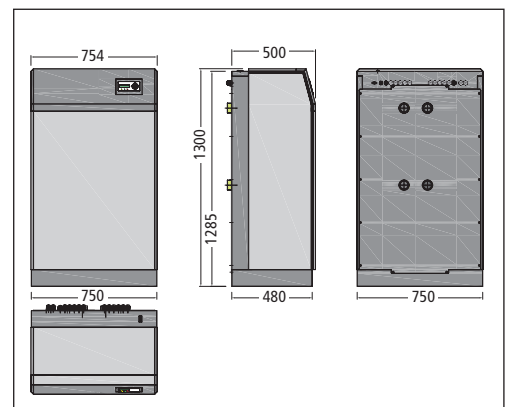
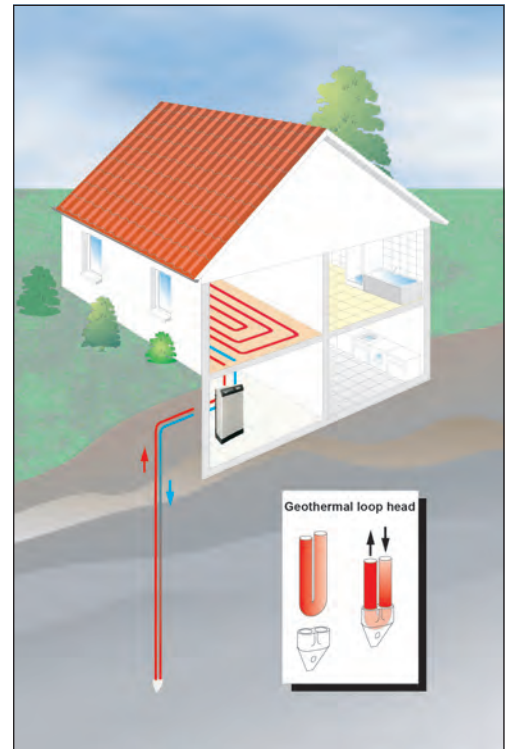

The minimal dimensions are advantageous in comparison to the capacity.

Technical Data DS 5050.3 T (R407C)

		5030.3 T	5037.3 T	5044.3 T	5050.3 T
Power cons./output W10/6//B8/4//W35 ¹⁾	kW ²⁾	5.1/ 28.5	6.5/ 34.9	7.4/ 41.6	8.4/ 46.9
Annual energy rate		5.6	5.4	5.6	5.6
Groundwater flow rate	m ³ /h (Δt=4K)	5.0	6.1	7.4	8.3
Pressure loss in the evaporator	mWS	1.3	1.6	1.7	1.8
Heating water flow rate	m ³ /h (Δt=5K)	4.9	6.0	7.2	8.1
Pressure loss in the condenser	mWS	1.0	1.1	1.3	1.3
Power cons./output B0/W35 ³⁾	kW ²⁾	5.0/23.0	6.3/28.0	7.3/33.6	8.2/37.7
Annual energy rate		4.6	4.4	4.6	4.6
Water-glycol flow rate (B0/W35)	m ³ /h (Δt=4K)	4.3	5.1	6.2	7.0
Pressure loss in the evaporator	mWS	1.0	1.1	1.2	1.3
Heating water flow rate (B0/W35)	m ³ /h (Δt=5K)	4.0	4.8	5.8	6.5
Pressure loss in the condenser	mWS	0.5	0.6	0.7	0.7
Power cons./output B5/W35 ³⁾	kW ²⁾	5.0/26.3	6.4/32.2	7.4/38.4	8.3/43.3
Annual energy rate		5.2	5.0	5.2	5.2

Usage limit
Compressor

B-5/W50, W5/W55
Tandem-Vollhermetic-Scroll

Electrical information for 400 V/3 AC/50 Hz

Starting current	A	34	36	41	45
Max. operating current	A	20	22	26	30
Main fuse, prov. by cust., slow-acting	A	25	25	32	32
Main fuse, prov. by cust., quick-acting	A	10	10	10	10

Dimensions, weights, connections

Number of Scroll compressors		2	2	2	2
Filling compound	Liter	2.72	3.37	3.2	3.4
Weight	kg	220	246	263	269
Connections: heat source/use		R2" ext.			
Sizes L x B x H	mm	750 x 1300 x 500			

¹⁾ Heat source ground water with intermediate circuit. For details refer to our product range. The energy rates are basing on this system configuration. ²⁾ Tolerances stated in EN 12900 apply for the performance data listed above. ³⁾ Fluid 70% water, 30 % Ethylene-Glycol.



WATERKOTTE GmbH
Gewerkenstraße 15
D-44628 Herne
Tel.: +49 (0) 23 23 / 93 76 - 0
Fax: +49 (0) 23 23 / 93 76 - 99
E-Mail: info@waterkotte.de
www.waterkotte.de



WATERKOTTE
EuroTherm AG
Industriestraße 54
CH-1791 Courtaman
Tel.: +41 (0) 26 6840633
Fax: +41 (0) 26 6840634
info@eurothermag.ch
www.eurothermag.ch



WATERKOTTE Austria GmbH
Leisbach 32
A-9074 Keutschach
Tel.: +43 (0) 463 29403 0
Fax: +43 (0) 463 29403 018
wouk@waterkotte.at
www.waterkotte.at



Mondial Géothermie Sarl
ZAC de la Bruyère
18 bis rue de la Bruyère
F-31120 Pinsaguel
Tel.: +33 (0) 5 34 57 21 90
Fax: +33 (0) 5 34 57 14 67
mondialgeothermie@wanadoo.fr
www.mondialgeothermie.fr



Hennlich Industrietechnik spol.s.r.o.
Ceskolipská 9
CZ-41201 Litomerice
Tel.: +42 (0) 416 711 250
Fax: +42 (0) 416 711 299
sumera@hennlich.cz
www.hennlich.cz



Nutherm Ltd.
Sallybrook, Manorcunnigham
Letterkenny
IE-Co Donegal, Ireland
Tel.: +353 (0) 74 91 57893
Fax: +353 (0) 74 91 57856
UK Office
SATRA Innovation Park
Rockingham Road
Kettering, Northants, NN16 9JH, UK
Tel. +44 (0) 1536 533280
info@nutherm.eu
www.nutherm.eu



Waterkotte Nederland
Waterkotte Warmtepompen BV
Postadres: Hoekstraat 7a
5447 PA Rijkevoort (NL)
Tel.: +31 (0) 485-325573
Fax: +31 (0) 485-372337
info@waterkotte.nl
www.waterkotte.nl

Your local WATERKOTTE system partner: